

## Product data sheet



Materialnumber	9009100120000
Thread Size	M12
Thread Range	M12 - M24
Surface	bright
Internal Cooling	without
Type	VA R40

### Characteristics

Surface	bright
Internal Cooling	without
Type	VA R40
Thread Size	M12
Thread Range	M12 - M24
Norm	DIN 376
Norm 2	DIN 2184-1
Shank Form	straight shank
Form	C
Cutting Direction	right-hand
Tolerance Class	ISO2/6H
Hole Type	Blind Hole
Flute	40° right spiral
Color Ring	Blue Ring
Length Grinding	2-3 speeds
Threading Type	M
Full Length	110.000 mm
Length Threading	18.500 mm
Flute Length	45.000 mm
Useable Length	49.000 mm



### Gühring KG

Herderstraße 50-54,  
72458 Albstadt  
T.: +49 7431 17 0  
F.: +49 7431 17 297

Shank Length	0.000 mm
Diameter Threading Core	10.200 mm
Diameter Shank	9.000 mm
Threading Gradient	1.750 mm
Diameter Tolerance Field	h9
Additional Info	Internal Threads
EBEZ	ZL-GBO-M 03RGBR-N
Tool Type	Taps

## Hints

---

- i** CAD data and further information are available after registration in the shop.
- ⚠** All information is indicative. The actual achievable cutting speeds and feeds depend on the respective processing conditions. We recommend appropriate cutting tests.



## Gühring KG

Herderstraße 50-54,  
72458 Albstadt  
T.: +49 7431 17 0  
F.: +49 7431 17 297

## Cutting data

Subgroup	Strength/Hardness	Cutting speed	Feed	Drive	Feed Rate
Stainless steels, sulphured	900 N/mm <sup>2</sup>	8 m/min		212 rev./min	
Bronze long-chipping	1,000 N/mm <sup>2</sup>	12 m/min		318 rev./min	



### Gühring KG

Herderstraße 50-54,  
72458 Albstadt

T.: +49 7431 17 0

F.: +49 7431 17 297

## Technical drawing

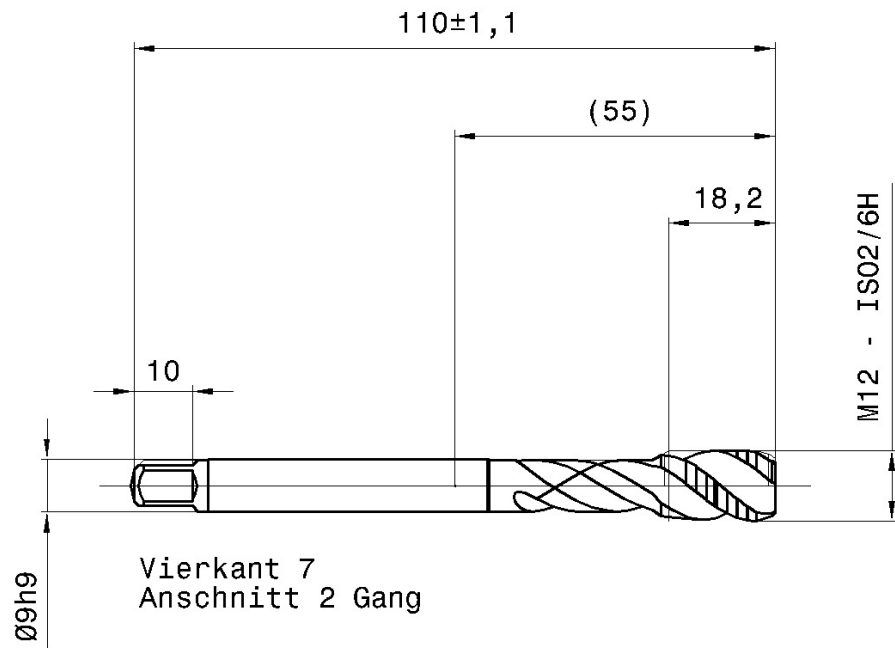

GÜHRING	
Artikel-Nr.	910 12,000
Beschreibung	GEWINDEBOHRER
Schneidstoff	PM HSS-E
Beschichtung	BLANK
Kuehlung	-
Schneiden	3

Diese Zeichnung ist Eigentum der Fa. Gühring KG und darf nicht an Dritte weitergegeben werden.  
 Bearbeitungs- und Zeichnungsprüfung (auf Richtigkeit und Vollständigkeit) obliegen dem Kunden.



### Gühring KG

Herderstraße 50-54,  
 72458 Albstadt  
 T.: +49 7431 17 0  
 F.: +49 7431 17 297