



REF. 1511

BUT WELDING METAL EXPANSION JOINT



Size : DN 25 to 250
Ends : But Welding
Min Temperature : - 20°C
Max Temperature : + 300°C
Max Pressure : 16 Bars
Specifications : Axial movement
With internal liner
Stainless steel bellow

Materials : Steel ends



REF. 1511

BUT WELDING METAL EXPANSION JOINT

SPECIFICATIONS :

- Axial movement
- Respect the flow direction indicated by the arrow
- Stainless steel bellow
- With internal liner
- But welding ends

USE :

- For common fluids
- Min Temperature Ts : - 20°C
- Max Temperature Ts :+ 300°C
- Max Pressure Ps : 16 bars (see graph)
- Axial movement only

PRESSURE / TEMPERATURE GRAPH (STEAM EXCLUDED) :

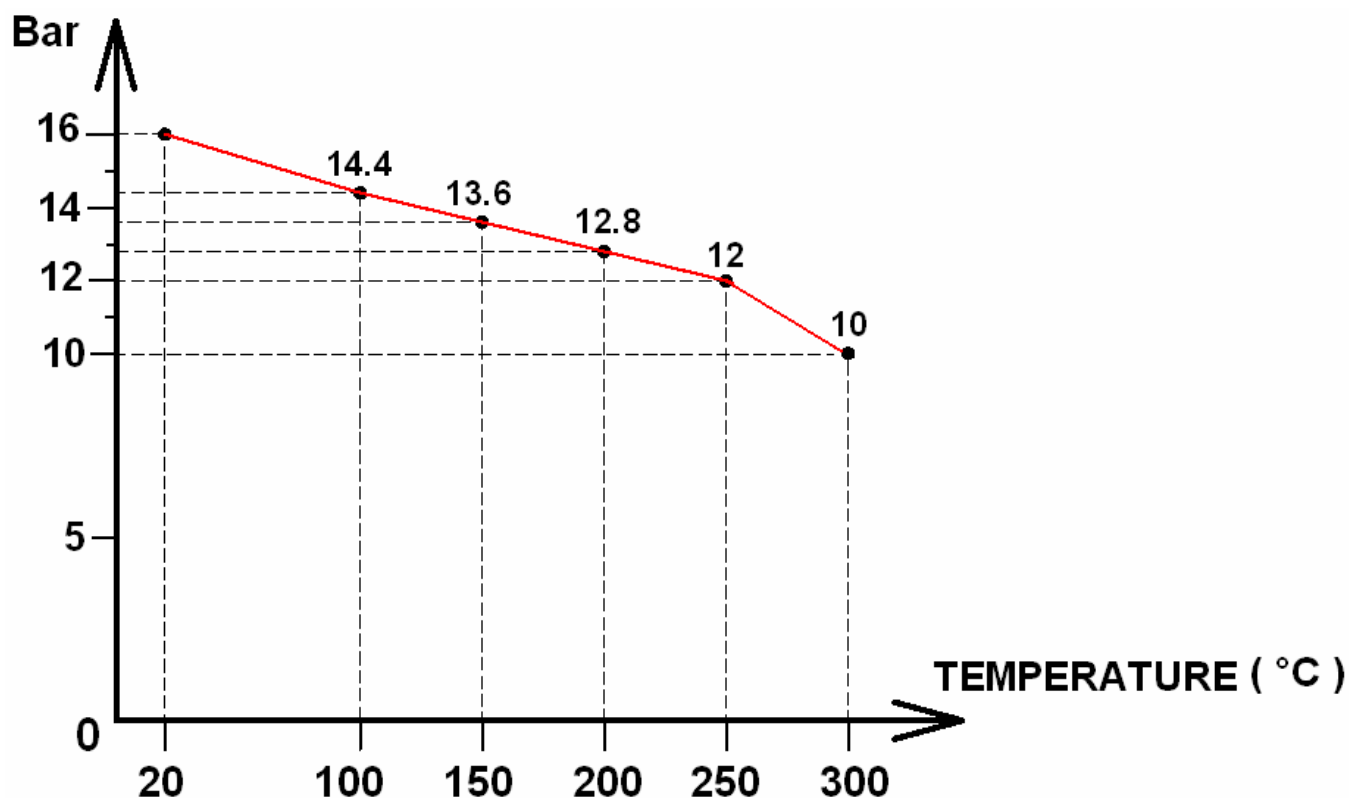

RANGE :

- Steel But Welding ends from DN25 to DN250



BUT WELDING METAL EXPANSION JOINT

MATERIALS :

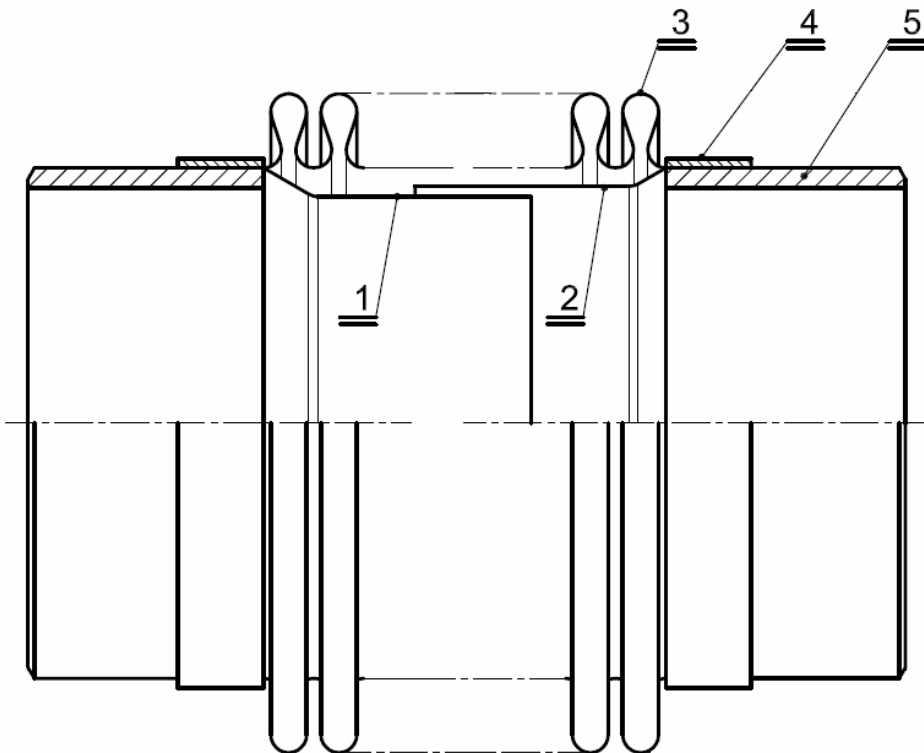

Item	Designation	Materials
1	Internal liner	SS 321
2	Internal liner	SS 321
3	Bellow	SS 321
4	Band	SS 321
5	Ends	Steel St 37.2



REF. 1511

BUT WELDING METAL EXPANSION JOINT

SIZE (in mm) :

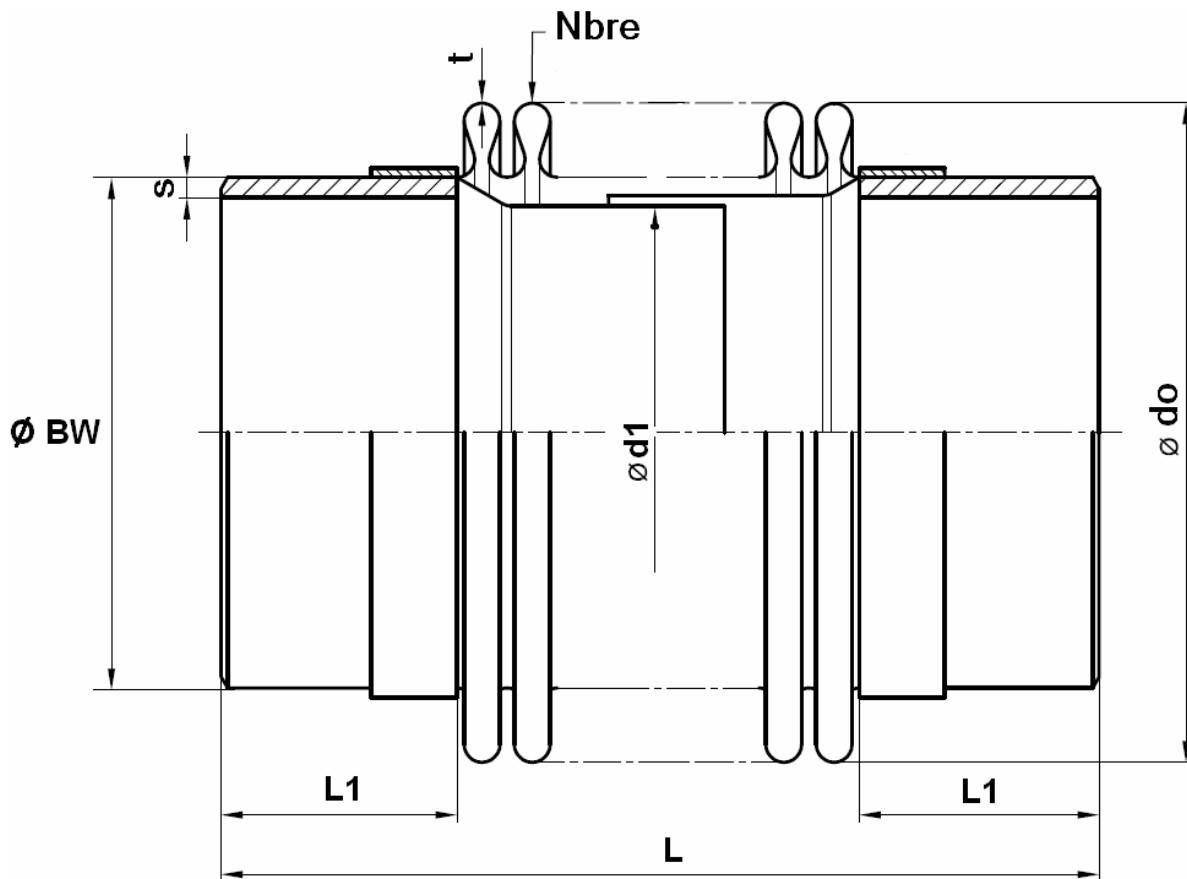

	DN	25	32	40	50	65	80	100	125	150	200	250
Ref. 1511	L	185	185	200	270	260	275	310	310	350	330	360
	L1	55	55	50	75	80	75	60	85	60	65	60
	Ø BW	38	42.4	48.3	60.3	76.1	88.9	114.3	139.7	168.3	219.1	273
	Ø do	48.8	55.6	61	77	96	112	141	165	201	252	325.8
	Ø d1	32	36	41.4	53.5	70	78	103.5	127.3	156	207	261
	s	2.6	2.6	2.6	2.9	2.9	3.2	3.6	4	4.5	6.3	6.3
	T	0.3	0.3	0.3	0.4	0.4	0.5	0.6	0.6	0.6	0.8	1
	Waves Nbre	17	17	17	20	16	15	20	16	20	16	14
	Weight (Kg)	0.37	0.44	0.53	1.11	1.37	1.86	2.94	3.89	5.85	9.4	13.97



REF. 1511

BUT WELDING METAL EXPANSION JOINT

MOVEMENTS (in mm) :

DN	25	32	40	50	65	80	100	125	150	200	250
Axial Movement	± 11	± 10	± 13	± 20	± 20	± 25	± 32	± 33	± 40	± 33	± 40

STANDARDS :

- Fabrication according to ISO 9001 : 2008
- DIRECTIVE 97/23/CE : CE N° 0036
Risk category II

ADVICE : Our opinion and our advice are not guaranteed and SFERACO shall not be liable for the consequences of damages.
The customer must check the right choice of the products with the real service conditions.



REF. 1511

BUT WELDING METAL EXPANSION JOINT

INSTALLATION INSTRUCTION :

Stainless steel compensators are designed for the absorption of previously specified movements under specific pressure and temperature conditions. So that the maximum service life is achieved, the following items must be observed during installation.

1. Pipeline:

Prior to fitment of the compensator it must be ensured that:

- The route of the pipeline is straight.
- The expansion tallies with that of the chosen compensator.
- The fixed points are dimensioned so that they can absorb the reaction forces and stiffness rate that arise during use.
- The pipeline is limited by fixed points.
- Only one compensator is not subjected to torsion.

2. Pipe route:

The fixed points and route bearings must be located so that:

- The compensator is not subjected to the weight of the pipeline.
- Sagging is prevented by the including of fixed or loose bearings.
- Suspension in self-aligning bearings is avoided. Plain or roller bearings are to be used as the guide bearings.

3. Location of the guide bearings:

- The distance between the compensator and the 1st bearing may be a maximum of 4 times the pipe diameter.
- The distance between the 1st and the 2nd bearing may be a maximum of 14 times the pipe diameter.
- The distance between the remaining pipe bearings may be a maximum of 21 times the pipe diameter. This distance may have to be reduced, where this is required for the inherent stability of the pipe.

4. The following items must be taken into account during installation:

- The possibly provided protective covering of the bellows may only be removed after installation.
- Possible pretensioning devices may only be removed after installation.
- On compensators fitted with an arrow, check that the direction of the arrow matches the direction of flow.
- The bellows must be protected from welding, plaster and mortar spatter.
- During handling, ensure that the bellows does not come into contact with tools or lifting equipment. All lifting must take place by means of the eyes, welded ends or flanges.
- The installation length must agree with the installation gap.
- When insulating the pipeline, the bellows must be previously sheathed with a thin sheet of stainless steel.

5. Transportation and storage of the compensator:

- During transportation and storage, the compensator must be protected from moisture and all manner of fouling.
- Storage must take place on a flat, firm timber base.
- Bending due to heavy connections components must be prevented by timber supports (not in way of the bellows).

MAINTENANCE OF THE COMPENSATORS

A correctly dimensioned and fitted compensator requires no special maintenance. It is however recommended that specific characteristics be observed during routine inspections, so as to avoid severe damage.

1. Transportation and handling damage:

- Dents, abrasion and scratching due to incorrect handling.
- Corrosion due to unexpected environmental effects, such as salts, chemicals, etc.

2. Damage due to assembly faults:

- Fitment of the compensator at a different position to that initially intended.
- Greater inaccuracies in the pipeline run than presumed.
- Premature or delayed removal of the assembly aids.
- Fitment of the compensator with baffle againsts the direction of flow.
- Bellows damaged by welding spatter.

3. Damage during use:

- Corrosion damage due to environmental effects, e.g. chloride.
- Corrosion damage, respectively limited movement due to a collection of firmly adhering dirt or due to hardening of the medium in the shafts.
- Fatigue failure due to unforeseen vibration or movement.

